



**SWITCH
SUPERIOR**
COMPACT HEAT EXCHANGER

SAVE ON YOUR ENERGY COSTS

THE **SWITCHSUPERIOR** COMPACT HEAT EXCHANGER

**CREATING PERFORMANCE
ENHANCING CLIMATES**

MULTIHEAT
INTERNATIONAL

SAVE ENERGY WHILST CREATING A HEALTHY POULTRY HOUSE CLIMATE

PLUG & PLAY HEAT EXCHANGER

Saving energy and optimising the climate inside a poultry house are top priorities for every poultry farmer. Temperature and ventilation play a big part in the ideal circumstances for poultry to perform. The SwitchSuperior Compact Heat Exchanger takes polluted, CO₂-rich air from the poultry house, and exchanges this for fresh, O₂-rich air. The built-in exchanger block takes heat from the outgoing air to warm the fresh incoming air, which substantially improves the poultry house climate.

Because you will need less heating for the incoming air, using the compact heat exchanger can save up to 80% on your energy consumption. The dry, warm, incoming air, results in dryer litter and therefore less foot sole problems. The poultry house will have a healthier climate because of the significantly lower ammonia, dust and odour-levels.

The SwitchSuperior by Multiheat is the first top-quality Compact Heat Exchanger in the poultry sector. Using the latest fabrication technologies, the exchanger block is made of high-end aluminum and has an outstanding heat-exchanging capacity. The powerful fans provide the perfect airflow. The housing of the SwitchSuperior is made of insulated polyester panels, which are durable, easy to clean and can't corrode.

- Available in 5000 m³/h (2.940 cfm) and 9000 m³/h (5.300 cfm)
- Heat recovery efficiency up to 80%
- Adjustable air supply unit
- Compact unit size
- Easy to install (and add to existing ventilation system)
- Easy to operate (through existing climate computer in the poultry house)
- Low maintenance, easy to clean and disinfect

KEEP THE HEAT INSIDE YOUR SHED:
SAVE DIRECTLY ON ENERGY COSTS
AND **IMPROVE** YOUR SHED **CLIMATE**



HOW IT WORKS

1. Warm, polluted air is taken out of the poultry house by the fan
2. This warm air heats up the exchanger block
3. Cold, fresh outside air is drawn through the warm exchanger block
4. Heated outside air is blown into the poultry house

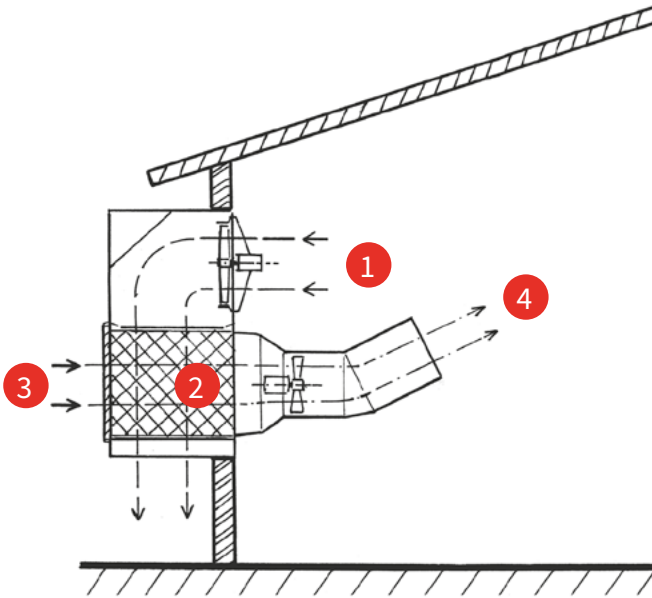

OUR EXPERTS HELP

Your success is our success, so we only benefit from the best use of our products. Our experts will help you to make the most of the SwitchSuperior. Depending on the poultry house size, number of animals and their weight, we can calculate the number of heat exchangers needed for the best results.

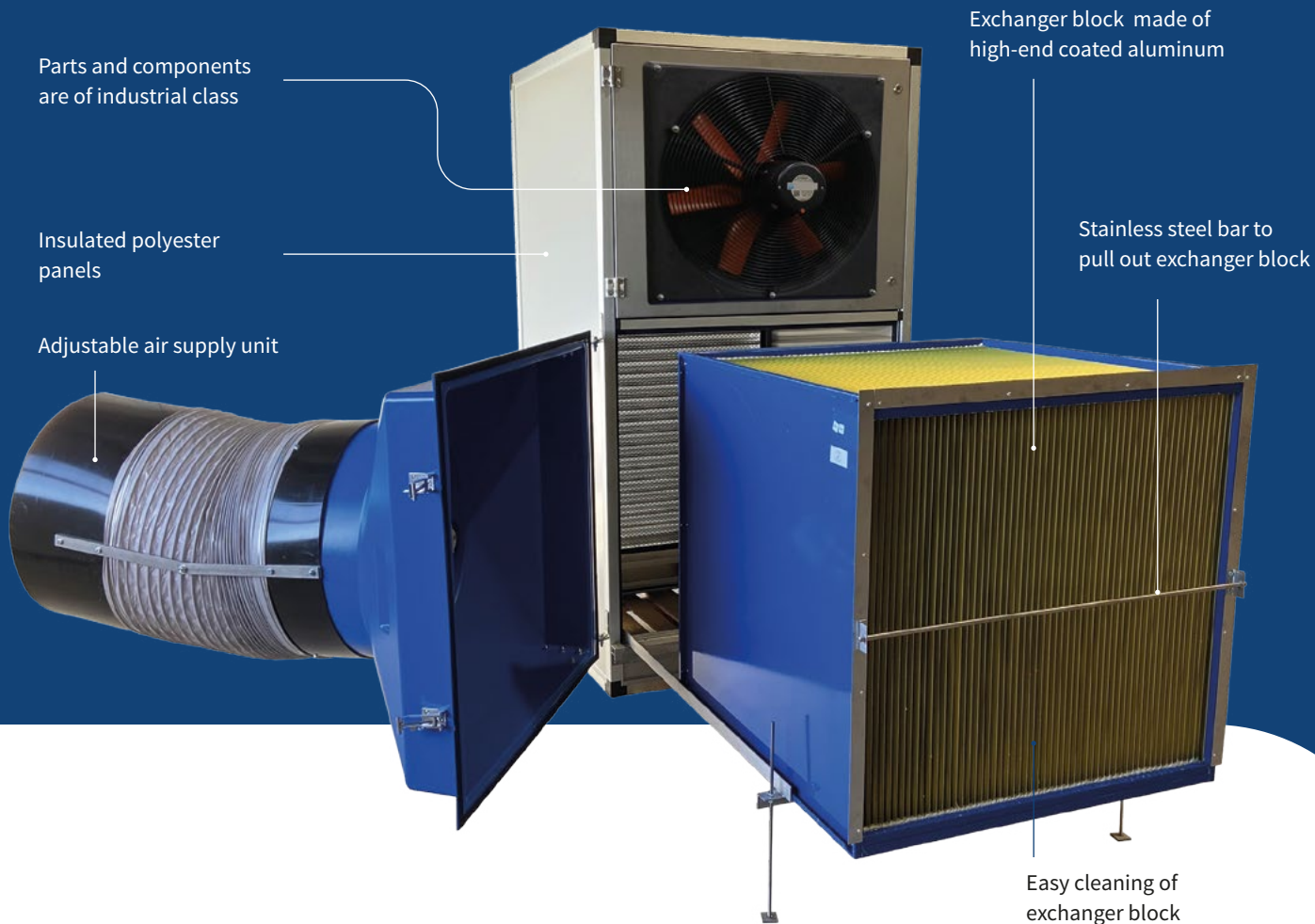

TECHNICAL DATA

SwitchSuperior **WTW-5000**

Heat recovery efficiency: up to 80%

Air capacity: 5.000 m³/h (2.940 cfm)

2x fan ø 50 cm (20")

l x w x h = 789 x 818 x 1751 mm. (excl. air supply unit)

Weight: 174 kg

l x w x h = 31" x 32" x 69" (excl. air supply unit)

Weight: 383 lb

SwitchSuperior **WTW-9000**

Heat recovery efficiency: up to 80%

Air capacity: 9.000 m³/h (5.300 cfm)

1x fan ø 63 cm (24") / 1x fan ø 56 cm (22")

l x w x h = 1089 x 1118 x 2101 mm. (excl. air supply unit)

Weight: 253 kg

l x w x h = 43" x 44" x 83" (excl. air supply unit)

Weight: 558 lb



Multiheat International is a well-established designer and manufacturer of warm water heaters, heat exchangers and indirect fired gas heaters, serving thousands of pig and poultry farmers all over the world. We pride ourselves in outstanding customer service, top quality and market leading products.

Please contact us as our staff is happy to explain you all the ins- and outs of our products.

MULTIHEAT

made by farmers, for farmers

 HARDINXVELD-GIESSENDAM, THE NETHERLANDS

 +31 342 712 033

 SALES@MULTIHEAT-INTERNATIONAL.COM

 WWW.MULTIHEAT-INTERNATIONAL.COM